

check-out counter lines



INTRAC
DESIGN & DISPLAY



Una linea flessibile di mobili cassa statici e motorizzati, disponibili in una gamma di modelli adatti ad ogni superficie di vendita. Robustezza, accessori, facilità d'uso unite ad un design rigoroso e minimalista consentono alle casse ONDA di adattarsi a creative soluzioni d'arredamento contemporaneo.

A flexible line of static and motorised check out counters, available in a wide range of models suitable for every size of store. Solidity, great range of accessories, easiness at use combined with a severe and minimalist design make the check out counters ONDA the right answer for the most creative solutions of modern interior design.



onda



Semplicity & Design
for a new sale concept

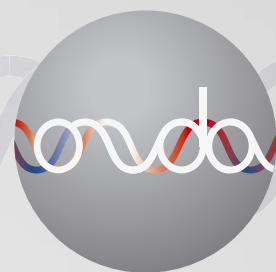

INTRAC
DESIGN & DISPLAY



ERGONOMIA - ERGONOMICS

Vano gambe - Legs compartment

Sezione vano gambe per postura in piedi con e senza ausilio

Section view of the legs compartment: standing posture with or without aid

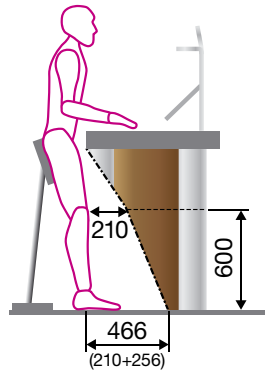
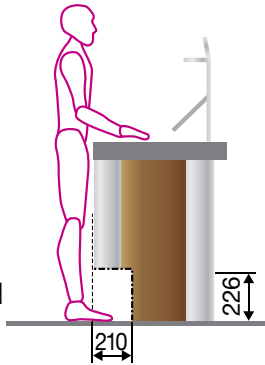

Sezione vano gambe per posizione seduta

Section view of the legs compartment: sitting posture

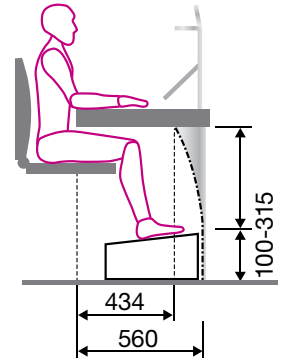

Zone di lavoro, campo visivo - Work areas, field of vision

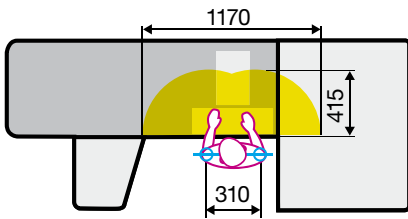

Spazio di prensione massimale
Maximum grasping area

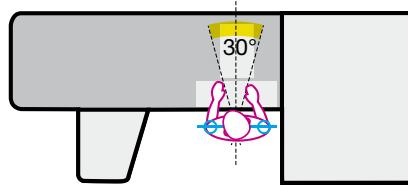

Campo visivo preferenziale orizzontale
Preferential horizontal field of vision

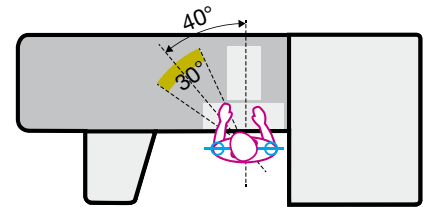

Campo visivo massimale orizzontale
Maximum horizontal field of vision

ALTEZZE - HEIGHTS

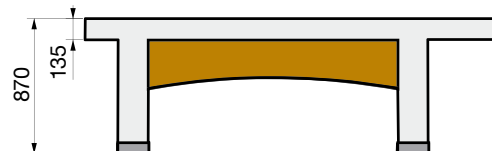

COLORI - COLOURS

GAMBE - LEGS



Alluminio anodizzato
Anodized aluminium

CARENATURA - TRIM

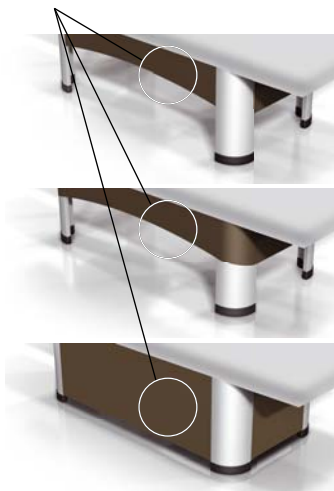

STANDARD



RAL 9006



RAL 9010



RAL 9005



RAL 3020

VERSIONI - VERSIONS

DX

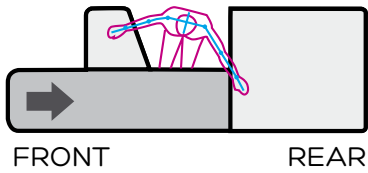

SX

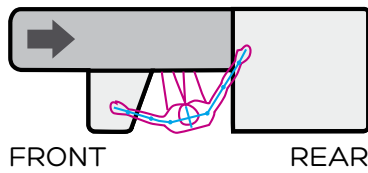

BTB

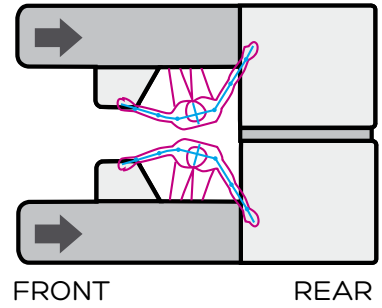

CARENATURA - TRIM

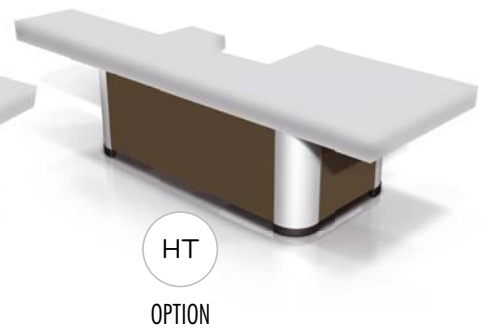

OPTIONAL

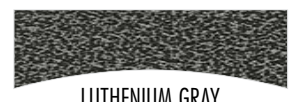



Technical features and strong points



Motore ad alta potenza di trascinamento
e con raffreddamento ad olio.
Nastro PVC monotela con possibilità di
personalizzazione con logo vulcanizzato.

*Motor with high belt drive power and oil
cooling. PVC single-cloth conveyor belt,
customizable with logo vulcanization.*



Frontale anteriore arrotondato in poliuretano morbido tipo
antiurto, autoestinguento e antifumo nero.

*Rear rounded panel made of soft, shock-proof, self-extinguishing,
anti-smoke, soft polyurethane.*



Parte superiore operativa in alluminio
anodizzato con protezione laterale in PVC
rigido antiurto di colore nero.

*Upper part in anodized aluminium with
lateral protection in shock-proof, black,
rigid PVC.*



Piano di lavoro/scanner in acciaio inox
rigidizzato, questo materiale consente
di coniugare perfettamente l'aspetto
estetico e quello funzionale (cassetto
optional).

*Central scanner module in stiffened,
stainless steel for a perfect combination
of style and functionality (possibility of
cash-drawer).*



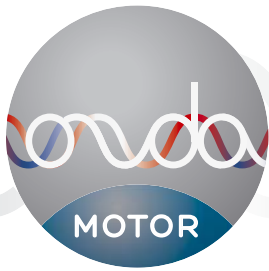

Quadro elettronico di comando
alloggiato in posizione ergonomica.

*Electronic control panel, placed in an
ergonomic position.*



Parte inferiore in alluminio anodizzato con angoli
arrotondati. Zoccolo di protezione in polipropilene di
colore nero. Carenature disponibili in 3 versioni.

*Lower part in anodized aluminium with rounded
corners. Legs bottom protection in black polypropylene.
Trims available in 3 versions.*

Modulo posteriore vasca (vasca larga L.1150/1060 e
vasca stretta L.530/575) in acciaio inox rigidizzato
e rinforzato, completa di frontale e paracolpi merce
arrotondato, in poliuretano morbido antiurto,
autoestinguente e antifumo, di colore nero

*Rear basin module (large basin L.1150/1060 and
small basin L.530/575) in stiffened, reinforced
stainless steel and complete with rounded, bumper
profile made of shock-proof, self-extinguishing, anti-
smoke, soft, black polyurethane.*



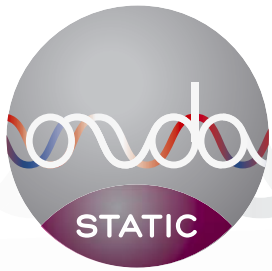

Carenatura laterale in acciaio verniciato, con predisposizione interna all'alloggiamento dei cavi elettrici.

Lateral trim in painted steel, with internal predisposition for wiring.



Piano in acciaio inox rigidizzato.

Reinforced, stainless steel shelf.



ACCESSORI - ACCESSORIES

Fronte Operatore (Front Cashier)

- 1A Protezione Scanner S-Elipse (S-Elipse Scanner Protection Assembly)
- 1B Protezione Scanner S-Elipse + Film Opaco (S-Elipse Scanner Protection Assembly with Opaque Stripe)
- 2 Attacco Tastiera - Porta Oggetti - POS (Connection for Keyboard, Object Holder, POS System)
- 3 Supporto Porta Oggetti (Object Holder)
- 4 Porta Tastiera - Porta Touch-Screen L 350 (Keyboard Support - Touch-Screen Support L350)
- 5 Lente Grandangolare (Wide-Angle Lens)
- 6 Supporto Fisso per PIN-PAD (Fixed Support for PIN-PAD)
- 7 Supporto Rotante per PIN-PAD (Rotating Support for PIN-PAD)
- 8 Gancio per Pistola Scanner (Scanner Holding Hook)
- 9 Cassetto Rendiresto 12/24/36 V (Cash Drawer 12/24/36 V)
- 10 Inserto Cassetto Rendiresto (Cash Insert Unit)
- 11 Deviamerze (Grocery Deviator)

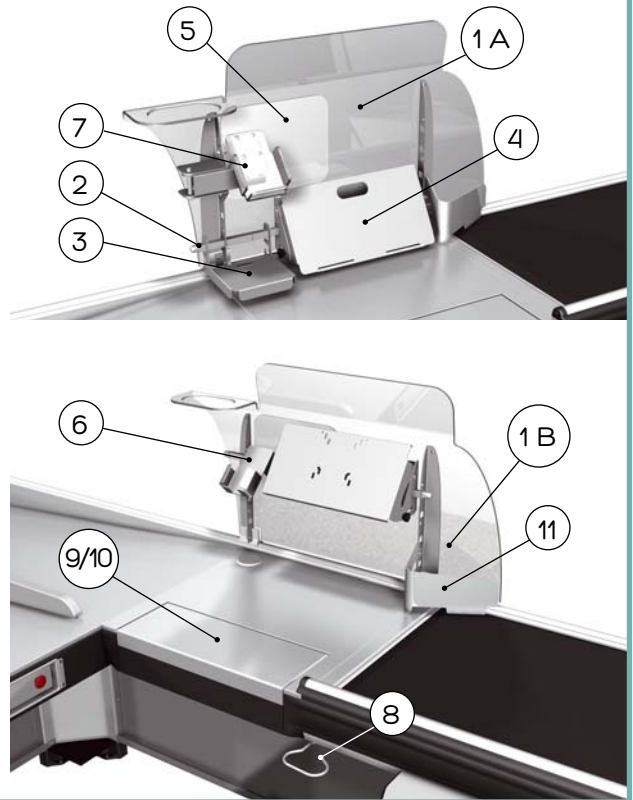

Funzionalità mobile cassa (Customer service accessories)

- 20 Prese Ausiliarie (Auxiliary Socket)
- 21 Canalina Passa-Cavi Interna Aggiuntiva (Additional Cable Channel)
- 22 Raccoglibriciole (Crumb Collector)
- 22A Spazzola per Raccoglibriciole (Brush for Crumb Collector)
- 23 Piano CPU-Servizio Fisso L.1150/1060 (CPU-Service Fixed Shelf L.1150/1060)
- 24 Piano CPU-Servizio Scorrevole L.1150/1060 (CPU-Service Sliding Shelf L.1150/1060)
- 25 Fissaggio a Pavimento (Fastening to the ground Assembly)
- 26 Sgabello Cassa con Schienale (Check-Out Stool With Back)
- 27 Pedana Regolabile+Alloggiamento pedali (Adjustable Footboard with Pedal Housing)
- 28 Cassetto Servizio Sottovasca (Under Basin Drawer)
- 29 Cassetto Servizio Sottopiano (Under Shelf Drawer)
- 30 Chiusura con Porta (Closing Door Assembly)
- 31 Pedana Pavimento (Platform Assembly)
- 32 Protezione Plexi Cassiera (Cashier's Plexi protection)
- 33 Protezione Plexi Registratore Cassa (Cash-Register Plexi protection)
- 34 Carenatura Bassa Avvolgente - SWT (Short Wrapping Trim - SWT)
- 35 Carenatura Alta - HT (High Trim - HT)

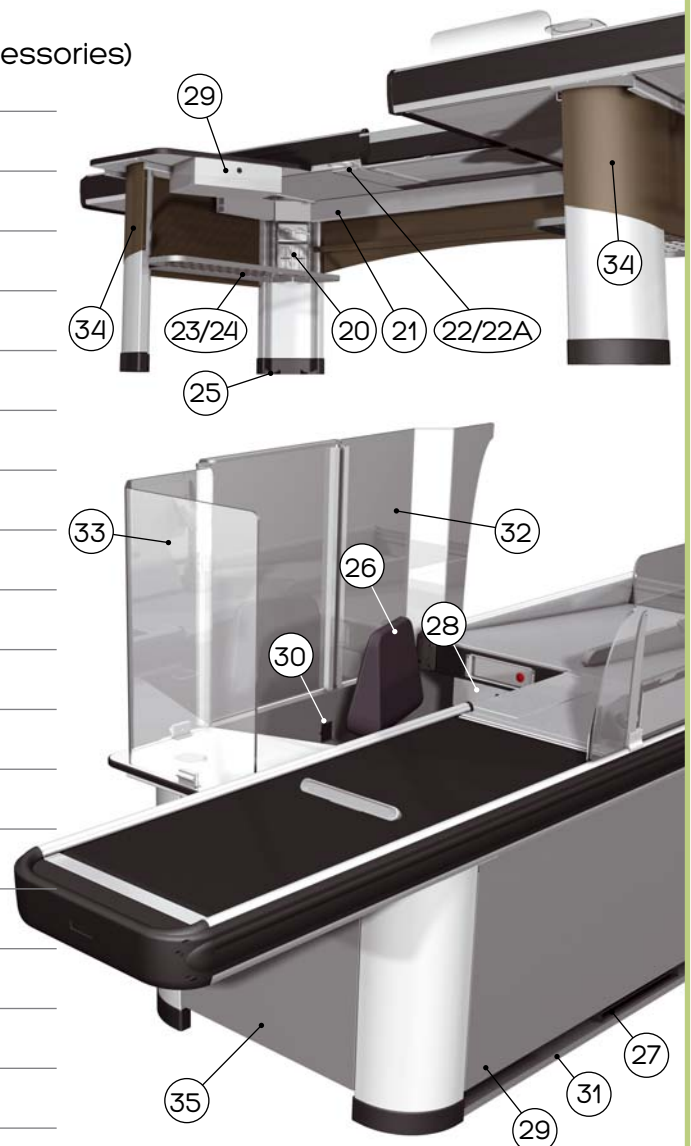



NSV



Modello Model	L	N	S	V	A	B	C	H
	mm	mm	mm	mm	mm	mm	mm	mm
NSV 170	1700	700	350	650	600	420	30	870
NSV 200	2000	700	350	950	600	420	30	870
NSV 230	2300	1000	350	950	800	420	130	870
NSV 260	2600	1300	350	950	790	585	360	870
NSV 290	2900	1600	350	950	790	585	660	870
NSV 320	3200	1600	350	1250	860	585	590	870
NSV 350	3500	1900	350	1250	860	585	890	870

ACCESSORI - ACCESSORIES

1A	•
1B	•
2	•
3	•
4	•
5	•
6	•
7	•
8	•
9	
10	
11	•

20	•
21	•
22	•
22A	•
23	•
24	320-350
25	•
26	•
27	•
28	•
29	•
30*	•
31*	•
32*	•
33*	•
34	•
35	•

* NO BTB

40A	•
40B	•
41A	•
41B	•
41C	•
41D	•
41E	•
41F	•
42	•
43	•
45	200-350
46	•
47	•
48	290-350
49	260-350
50	•
51	•
52	290-350
53	•

DX

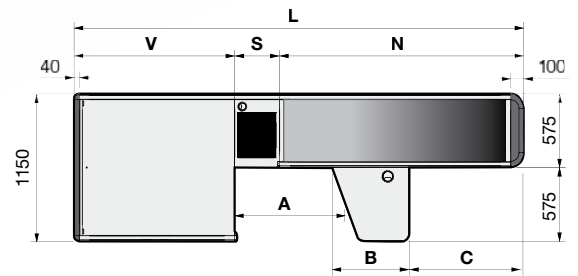

SX

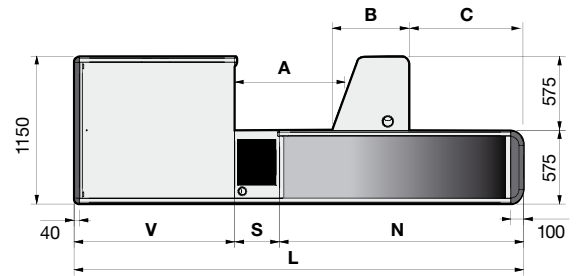

BTB

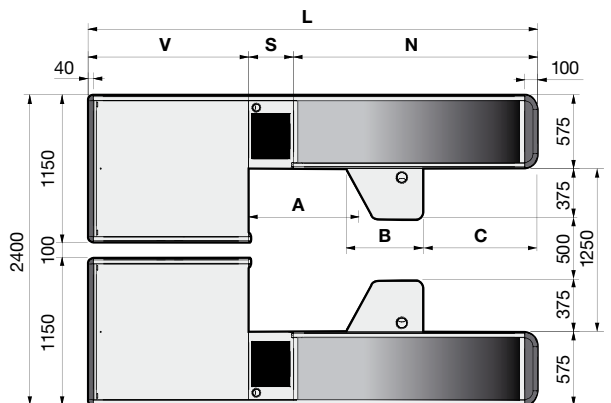



Modello Model	L	N	S	V	A	B	C	H
	mm	mm	mm	mm	mm	mm	mm	mm
NSCV 190	1900	700	550	650	800	420	30	870
NSCV 220	2200	700	550	950	800	420	30	870
NSCV 250	2500	1000	550	950	790	585	260	870
NSCV 280	2800	1300	550	950	790	585	560	870
NSCV 310	3100	1600	550	950	790	585	860	870
NSCV 340	3400	1600	550	1250	860	585	790	870
NSCV 370	3700	1900	550	1250	860	585	1090	870

ACCESSORI - ACCESSORIES

1A	<input type="checkbox"/>	20	<input type="checkbox"/>	40A	<input type="checkbox"/>
1B	<input type="checkbox"/>	21	<input type="checkbox"/>	40B	<input type="checkbox"/>
2	<input type="checkbox"/>	22	<input type="checkbox"/>	41A	<input type="checkbox"/>
3	<input type="checkbox"/>	22A	<input type="checkbox"/>	41B	<input type="checkbox"/>
4	<input type="checkbox"/>	23	<input type="checkbox"/>	41C	<input type="checkbox"/>
5	<input type="checkbox"/>	24	<input type="checkbox"/>	41D	<input type="checkbox"/>
6	<input type="checkbox"/>	25	<input type="checkbox"/>	41E	<input type="checkbox"/>
7	<input type="checkbox"/>	26	<input type="checkbox"/>	41F	<input type="checkbox"/>
8	<input type="checkbox"/>	27	<input type="checkbox"/>	42	<input type="checkbox"/>
9	<input type="checkbox"/>	28	<input type="checkbox"/>	43	<input type="checkbox"/>
10	<input type="checkbox"/>	29	<input type="checkbox"/>	45	<input type="checkbox"/>
11	<input type="checkbox"/>	30*	<input type="checkbox"/>	46	<input type="checkbox"/>
		31*	<input type="checkbox"/>	47	<input type="checkbox"/>
		32*	<input type="checkbox"/>	48	<input type="checkbox"/>
		33*	<input type="checkbox"/>	49	<input type="checkbox"/>
		34	<input type="checkbox"/>	50	<input type="checkbox"/>
		35	<input type="checkbox"/>	51	<input type="checkbox"/>
				52	<input type="checkbox"/>
				53	<input type="checkbox"/>

* NO BTB

DX

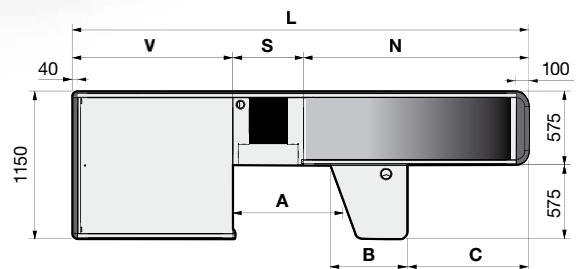

SX

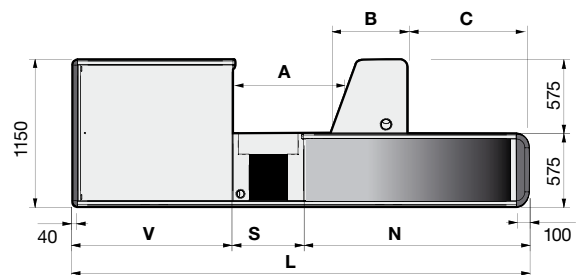

BTB

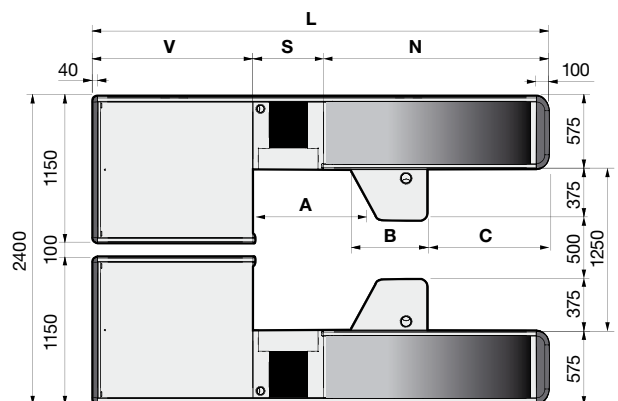

ACCESSORI - ACCESSORIES

Accessori servizio cliente (Function enhancement accessories)

- 40A Colonna Passacavi 100x70 (100x70 Cable Column)
- 40B Colonna Passacavi 2xø30 (2xø30 Cable Column)
- 41A Segnalatore Numero Cassa (Check-out Open/Closed Signal)
- 41B Segnalatore Numero Cassa a Deriva ("Daggerboard" Check-out Open/Closed Signal)
- 41C Segnalatore Num. Cassa a Fiocco ("Fiocco" Check-out Open/Closed Signal)
- 41D Segnalatore Num. Cassa Ovale ("Oval" Check-out Open/Closed Signal)
- 41E Segnalatore Num. Cassa a Vela Logo Bianco ("Vela" Check-out Open/Closed Signal white logo)
- 41F Segnalatore Num. Cassa a Vela Logo Multicolor ("Vela" Check-out Open/Closed Signal multi-color logo)
- 42 Spartimerce Vasca (Grocery Divider)
- 43 Chiusura Passaggio Carrello (Trolley Blocking Device)
- 45 Portasacchetti Posteriore (Rear Bag Holder)
- 46 Poggiasacchetti Posteriore (Rear Bag Rest)
- 47 Poggia+Porta Sacchetti Posteriore (Rear Bag Rest+Holder)
- 48 Portasacchetti Anteriore Laterale 2 Livelli (2-Level Lateral Front Bag-Holder)
- 49 Portasacchetti Anteriore 2 Livelli (2-Level Front Bag-Holder)
- 50 Poggiacesti Anteriore (Front Basket Rest)
- 51 Poggia+Porta Sacchetti Anteriore 2 Livelli (2-Level Front Bag Rest+Holder)
- 52 Gancio Portasacchetti Anteriore (Front Bag-Holder Hook)
- 53 Assieme Asta Cliente Successivo (Next Customer Assembly)

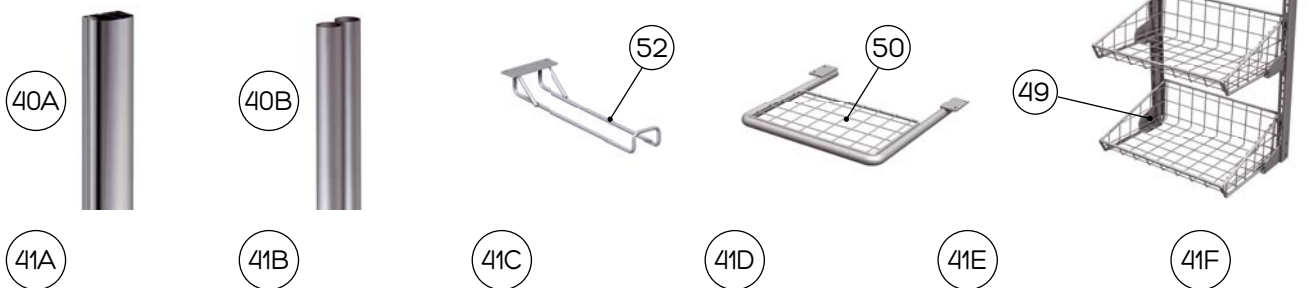
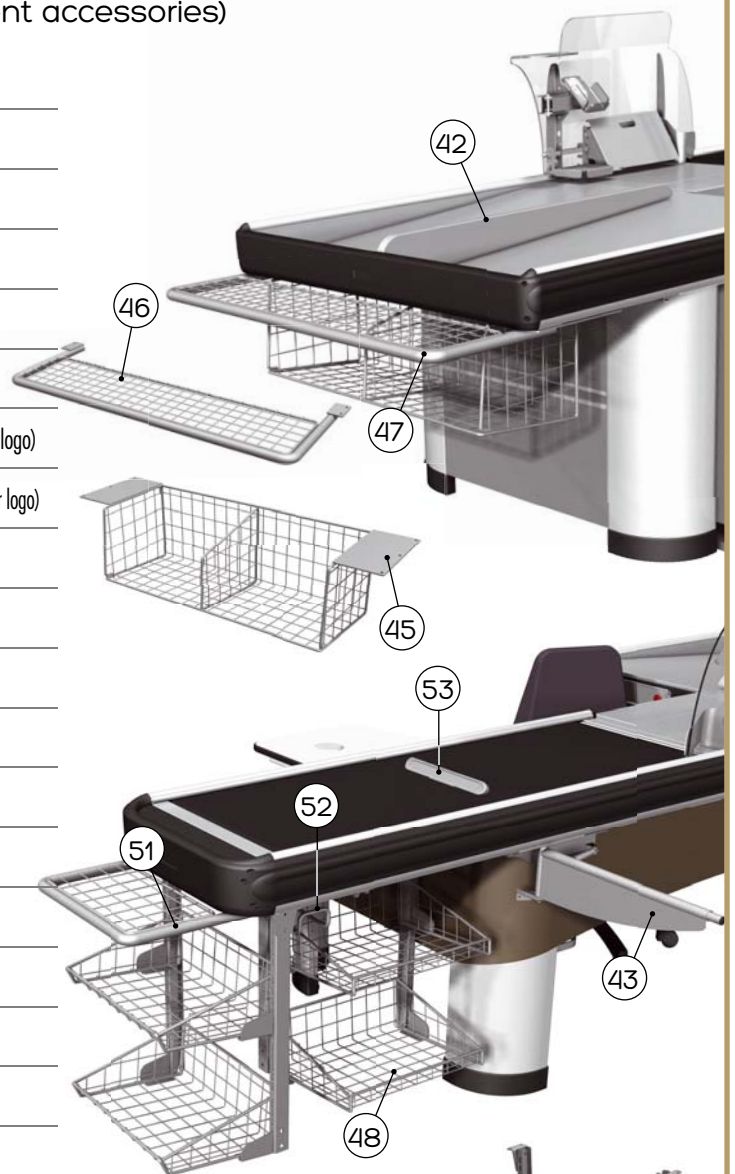



TANDEM



Modello Model	L	N	S	V	A	B	C	H
	mm	mm	mm	mm	mm	mm	mm	mm
TANDEM 315 R	1900	700	550	650	800	420	30	870
TANDEM 315 L	1900	700	550	650	800	420	30	870
TANDEM 375 R	2200	1000	550	650	790	585	260	870
TANDEM 375 L	2200	1000	550	650	980	585	60	870
TANDEM 410 R	2500	1000	550	950	790	585	310	870
TANDEM 410 L	2500	1000	550	950	790	585	310	870
TANDEM 465 R	2800	1300	550	950	790	585	560	870
TANDEM 465 L	2800	1300	550	950	1030	585	310	870

ACCESSORI - ACCESSORIES

- 1A
- 1B
- 2
- 3
- 4
- 5
- 6
- 7
- 8
- 9
- 10
- 11

- 20
- 21
- 22
- 22A
- 23
- 24
- 25
- 26
- 27
- 28
- 29
- 30
- 31
- 32
- 33
- 34
- 35

- 40A
- 40B
- 41A
- 41B
- 41C
- 41D
- 41E
- 41F
- 42
- 43
- 45 410-465
- 46 S2
- 47 S2
- 48 465
- 49 410-465
- 50 S1
- 51 S1
- 52 465
- 53

DX

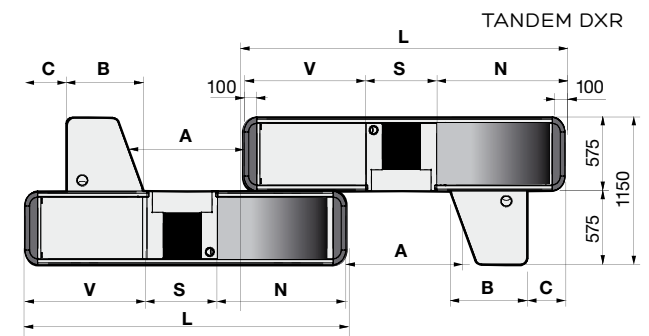

TANDEM DXL

SX

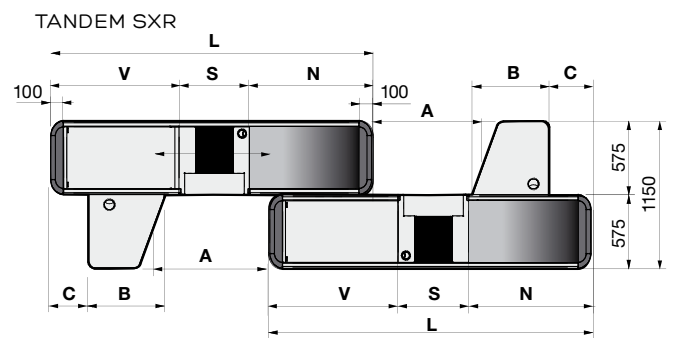

TANDEM SXL

S1 Disponibile cassa tandem anteriore (For TANDEM check-out available on the front check-out)
S2 Disponibile cassa tandem posteriore (For TANDEM check-out available on the rear check-out)



Modello Model	L	N	S	V	A	B	C	H
	mm	mm	mm	mm	mm	mm	mm	mm
NSVD 170	1700	700	350	650	-	585	60	870
NSVD 200	2000	700	350	950	-	585	60	870
NSVD 230	2300	1000	350	950	-	585	310	870
NSVD 260	2600	1300	350	950	-	585	590	870
NSVD 290	2900	1300	350	1250	-	585	590	870

DX

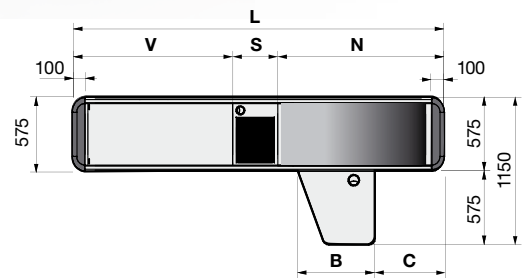

ACCESSORI - ACCESSORIES

1A	•
1B	•
2	•
3	•
4	•
5	•
6	•
7	•
8	•
9	
10	
11	•

20	•
21	•
22	•
22A	•
23	•
24	
25	•
26	•
27	•
28	
29	•
30	•
31	•
32	•
33	•
34	•
35	•

40A	•
40B	•
41A	•
41B	•
41C	•
41D	•
41E	•
41F	•
42	
43	•
45	200-290
46	•
47	•
48	260-290
49	230-290
50	•
51	•
52	260-290
53	•

SX

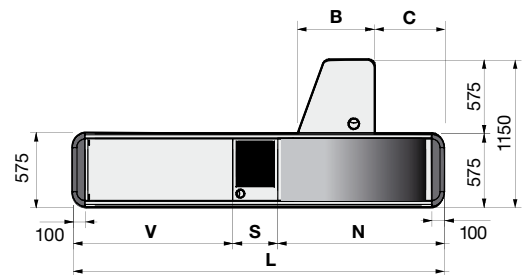



NSCVD



Modello Model	L	N	S	V	A	B	C	H
	mm	mm	mm	mm	mm	mm	mm	mm
NSCVD 190	1900	700	550	650	-	585	60	870
NSCVD 220	2200	700	550	950	-	585	60	870
NSCVD 250	2500	1000	550	950	-	585	310	870
NSCVD 280	2800	1300	550	950	-	585	590	870
NSCVD 310	3100	1300	550	1250	-	585	590	870
NSCVD 340	3400	1600	550	1250	-	585	790	870

DX

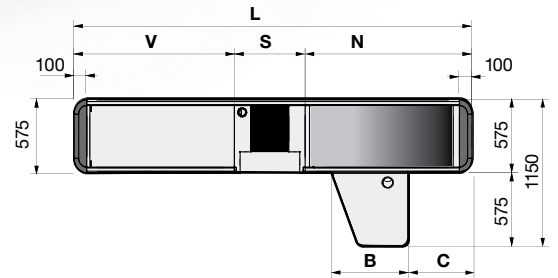

ACCESSORI - ACCESSORIES

1A	•
1B	•
2	•
3	•
4	•
5	•
6	•
7	•
8	•
9	•
10	•
11	•

20	•
21	•
22	•
22A	•
23	•
24	•
25	•
26	•
27	•
28	•
29	•
30	•
31	•
32	•
33	•
34	•
35	•

40A	•
40B	•
41A	•
41B	•
41C	•
41D	•
41E	•
41F	•
42	•
43	•
45	220-340
46	•
47	•
48	280-340
49	250-340
50	•
51	•
52	280-340
53	•

SX

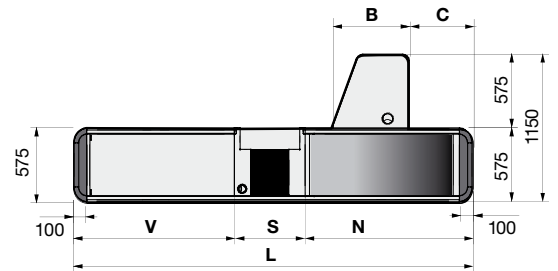



Modello Model	L	P	S	V	A	B	C	H
	mm	mm	mm	mm	mm	mm	mm	mm
PSV 170	1700	750	350	600	650	420	30	870
PSV 185	1850	900	350	600	800	420	30	870
PSV 200	2000	900	350	750	800	420	30	870

DX

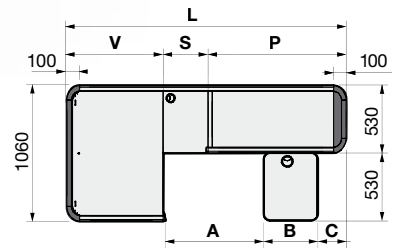

SX

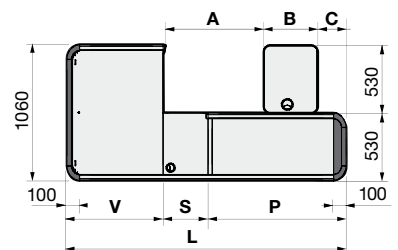

ACCESSORI - ACCESSORIES

1A	<input checked="" type="checkbox"/>
1B	<input checked="" type="checkbox"/>
2	<input checked="" type="checkbox"/>
3	<input checked="" type="checkbox"/>
4	<input checked="" type="checkbox"/>
5	<input checked="" type="checkbox"/>
6	<input checked="" type="checkbox"/>
7	<input checked="" type="checkbox"/>
8	<input checked="" type="checkbox"/>
9	<input type="checkbox"/>
10	<input type="checkbox"/>
11	<input type="checkbox"/>

20	<input checked="" type="checkbox"/>
21	<input checked="" type="checkbox"/>
22	<input type="checkbox"/>
22A	<input type="checkbox"/>
23	<input checked="" type="checkbox"/>
24	<input type="checkbox"/>
25	<input checked="" type="checkbox"/>
26	<input checked="" type="checkbox"/>
27	<input checked="" type="checkbox"/>
28	<input checked="" type="checkbox"/>
29	<input checked="" type="checkbox"/>
30	<input type="checkbox"/>
31	<input type="checkbox"/>
32	<input type="checkbox"/>
33	<input checked="" type="checkbox"/>
34	<input checked="" type="checkbox"/>
35	<input checked="" type="checkbox"/>

40A	<input checked="" type="checkbox"/>
40B	<input checked="" type="checkbox"/>
41A	<input checked="" type="checkbox"/>
41B	<input checked="" type="checkbox"/>
41C	<input checked="" type="checkbox"/>
41D	<input checked="" type="checkbox"/>
41E	<input checked="" type="checkbox"/>
41F	<input checked="" type="checkbox"/>
42	<input checked="" type="checkbox"/>
43	<input checked="" type="checkbox"/>
45	200
46	<input checked="" type="checkbox"/>
47	<input checked="" type="checkbox"/>
48	<input type="checkbox"/>
49	<input type="checkbox"/>
50	<input checked="" type="checkbox"/>
51	<input checked="" type="checkbox"/>
52	<input type="checkbox"/>
53	<input checked="" type="checkbox"/>



Modello Model	L	P	S	V	A	B	C	H
	mm	mm	mm	mm	mm	mm	mm	mm
PSCV 190	1900	750	550	600	850	420	30	870
PSCV 220	2200	900	550	750	800	420	230	870

DX

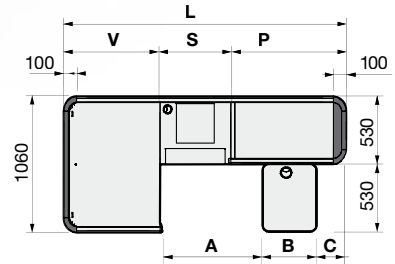

SX

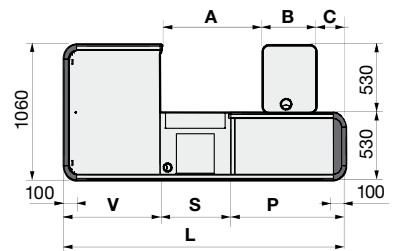

ACCESSORI - ACCESSORIES

1A	<input type="checkbox"/>	20	<input type="checkbox"/>	40A	<input type="checkbox"/>
1B	<input type="checkbox"/>	21	<input type="checkbox"/>	40B	<input type="checkbox"/>
2	<input type="checkbox"/>	22	<input type="checkbox"/>	41A	<input type="checkbox"/>
3	<input type="checkbox"/>	22A	<input type="checkbox"/>	41B	<input type="checkbox"/>
4	<input type="checkbox"/>	23	<input checked="" type="checkbox"/>	41C	<input type="checkbox"/>
5	<input type="checkbox"/>	24	<input type="checkbox"/>	41D	<input type="checkbox"/>
6	<input type="checkbox"/>	25	<input type="checkbox"/>	41E	<input type="checkbox"/>
7	<input type="checkbox"/>	26	<input type="checkbox"/>	41F	<input type="checkbox"/>
8	<input type="checkbox"/>	27	<input type="checkbox"/>	42	<input type="checkbox"/>
9	<input type="checkbox"/>	28	<input type="checkbox"/>	43	<input type="checkbox"/>
10	<input type="checkbox"/>	29	<input type="checkbox"/>	45	220
11	<input type="checkbox"/>	30	<input type="checkbox"/>	46	<input type="checkbox"/>
		31	<input type="checkbox"/>	47	<input type="checkbox"/>
		32	<input type="checkbox"/>	48	<input type="checkbox"/>
		33	<input type="checkbox"/>	49	<input type="checkbox"/>
		34	<input type="checkbox"/>	50	<input type="checkbox"/>
		35	<input type="checkbox"/>	51	<input type="checkbox"/>
				52	<input type="checkbox"/>
				53	<input type="checkbox"/>

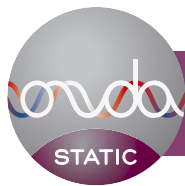

TANDEM



Modello Model	L	P	S	V	A	B	C	H
	mm	mm	mm	mm	mm	mm	mm	mm
TANDEM 300 R	1750	600	550	600	800	420	30	870
TANDEM 300 L	1750	600	550	600	800	420	30	870
TANDEM 370 R	2200	900	550	750	800	420	280	870
TANDEM 370 L	2200	900	550	750	800	420	280	870

DX

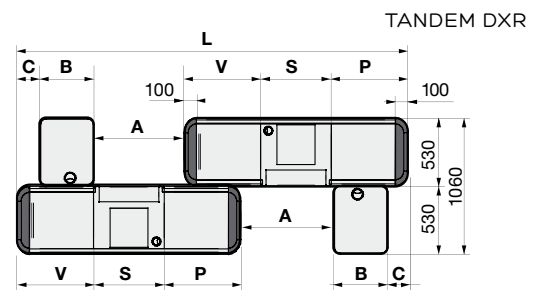

ACCESSORI - ACCESSORIES

1A	<input type="checkbox"/>	20	<input type="checkbox"/>	40A	S1
1B	<input type="checkbox"/>	21	<input type="checkbox"/>	40B	S1
2	<input type="checkbox"/>	22	<input type="checkbox"/>	41A	S1
3	<input type="checkbox"/>	22A	<input type="checkbox"/>	41B	S1
4	<input type="checkbox"/>	23	<input checked="" type="checkbox"/>	41C	S1
5	<input type="checkbox"/>	24	<input type="checkbox"/>	41D	S1
6	<input type="checkbox"/>	25	<input type="checkbox"/>	41E	S1
7	<input type="checkbox"/>	26	<input type="checkbox"/>	41E	S1
8	<input type="checkbox"/>	27	<input type="checkbox"/>	42	
9	<input type="checkbox"/>	28	<input type="checkbox"/>	43	<input type="checkbox"/>
10	<input type="checkbox"/>	29	<input type="checkbox"/>	45	370
11	<input type="checkbox"/>	30	<input type="checkbox"/>	46	S2
		31	<input type="checkbox"/>	47	S2
		32	<input type="checkbox"/>	48	
		33	<input type="checkbox"/>	49	370
		34	<input type="checkbox"/>	50	S1
		35	<input type="checkbox"/>	51	S1
				52	
				53	<input type="checkbox"/>

TANDEM DXL

SX

TANDEM SXR

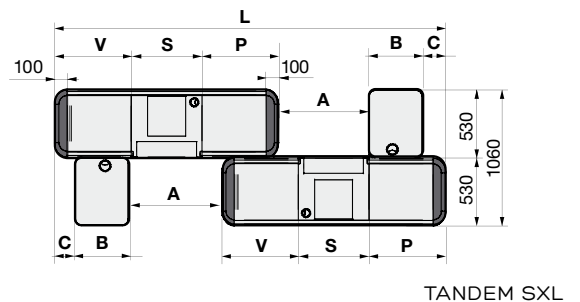

S1 Disponibile cassa tandem anteriore (For TANDEM check-out available on the front check-out)
S2 Disponibile cassa tandem posteriore (For TANDEM check-out available on the rear check-out)



Modello Model	L	P	S	V	A	B	C	H
	mm	mm	mm	mm	mm	mm	mm	mm
PSVD 125	1250	450	350	450	-	420	30	870
PSVD 155	1550	600	350	600	-	420	150	870
PSVD 170	1700	750	350	600	-	420	110	870
PSVD 200	2000	900	350	750	-	420	280	870

DX

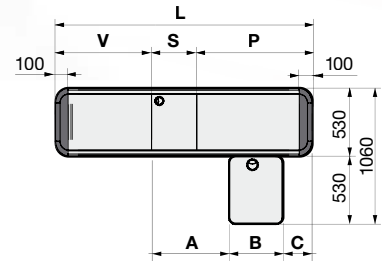

ACCESSORI - ACCESSORIES

1A	<input checked="" type="checkbox"/>
1B	<input checked="" type="checkbox"/>
2	<input checked="" type="checkbox"/>
3	<input checked="" type="checkbox"/>
4	<input checked="" type="checkbox"/>
5	<input checked="" type="checkbox"/>
6	<input checked="" type="checkbox"/>
7	<input checked="" type="checkbox"/>
8	<input checked="" type="checkbox"/>
9	<input type="checkbox"/>
10	<input type="checkbox"/>
11	<input type="checkbox"/>

20	<input checked="" type="checkbox"/>
21	<input checked="" type="checkbox"/>
22	<input type="checkbox"/>
22A	<input type="checkbox"/>
23	<input checked="" type="checkbox"/>
24	<input type="checkbox"/>
25	<input checked="" type="checkbox"/>
26	<input checked="" type="checkbox"/>
27	<input checked="" type="checkbox"/>
28	<input type="checkbox"/>
29	<input checked="" type="checkbox"/>
30	<input type="checkbox"/>
31	<input type="checkbox"/>
32	<input type="checkbox"/>
33	<input checked="" type="checkbox"/>
34	<input checked="" type="checkbox"/>
35	<input checked="" type="checkbox"/>

40A	<input checked="" type="checkbox"/>
40B	<input checked="" type="checkbox"/>
41A	<input checked="" type="checkbox"/>
41B	<input checked="" type="checkbox"/>
41C	<input checked="" type="checkbox"/>
41D	<input checked="" type="checkbox"/>
41E	<input checked="" type="checkbox"/>
41F	<input checked="" type="checkbox"/>
42	<input type="checkbox"/>
43	<input checked="" type="checkbox"/>
45	200
46	<input checked="" type="checkbox"/>
47	<input checked="" type="checkbox"/>
48	<input type="checkbox"/>
49	200
50	<input checked="" type="checkbox"/>
51	<input checked="" type="checkbox"/>
52	<input type="checkbox"/>
53	<input checked="" type="checkbox"/>

SX

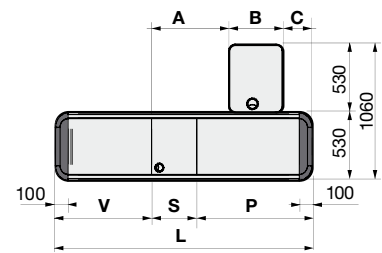

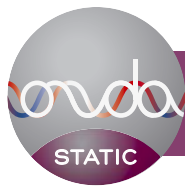

PSCVD

STATIC



Modello Model	L	P	S	V	A	B	C	H
	mm	mm	mm	mm	mm	mm	mm	mm
PSCVD 145	1450	450	550	450	-	420	30	870
PSCVD 175	1750	600	550	600	-	420	150	870
PSCVD 190	1900	750	550	600	-	420	110	870
PSCVD 220	2200	900	550	750	-	420	280	870

DX

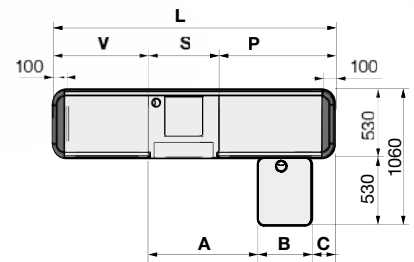

ACCESSORI - ACCESSORIES

- 1A
- 1B
- 2
- 3
- 4
- 5
- 6
- 7
- 8
- 9
- 10
- 11

- 20
- 21
- 22
- 22A
- 23
- 24
- 25
- 26
- 27
- 28
- 29
- 30
- 31
- 32
- 33
- 34
- 35

- 40A
- 40B
- 41A
- 41B
- 41C
- 41D
- 41E
- 41F
- 42
- 43
- 45 220
- 46
- 47
- 48
- 49 220
- 50
- 51
- 52
- 53

SX

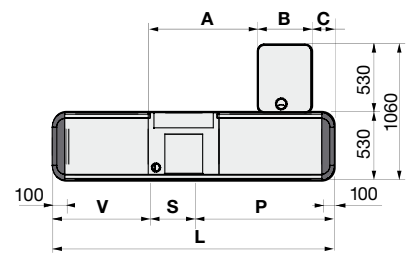



Avancasse



FM

FLF

LMD

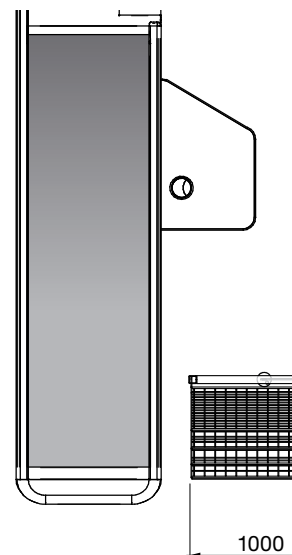
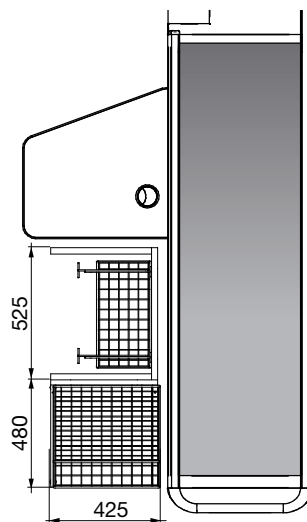
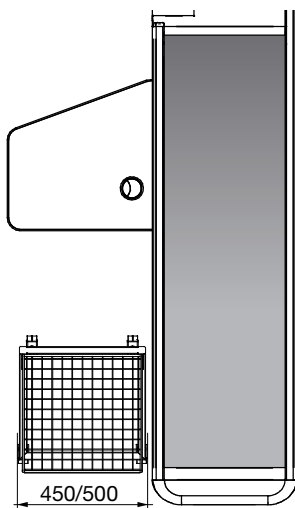
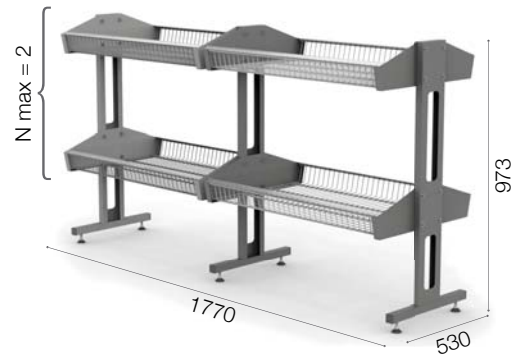
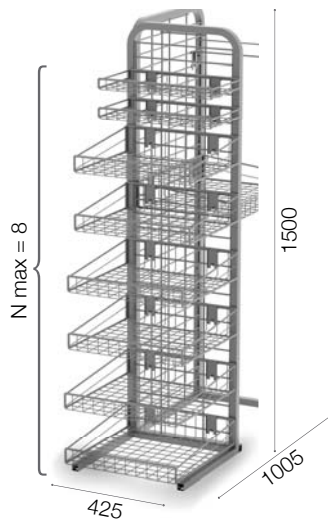
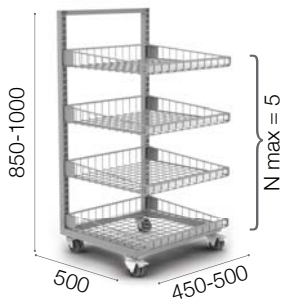

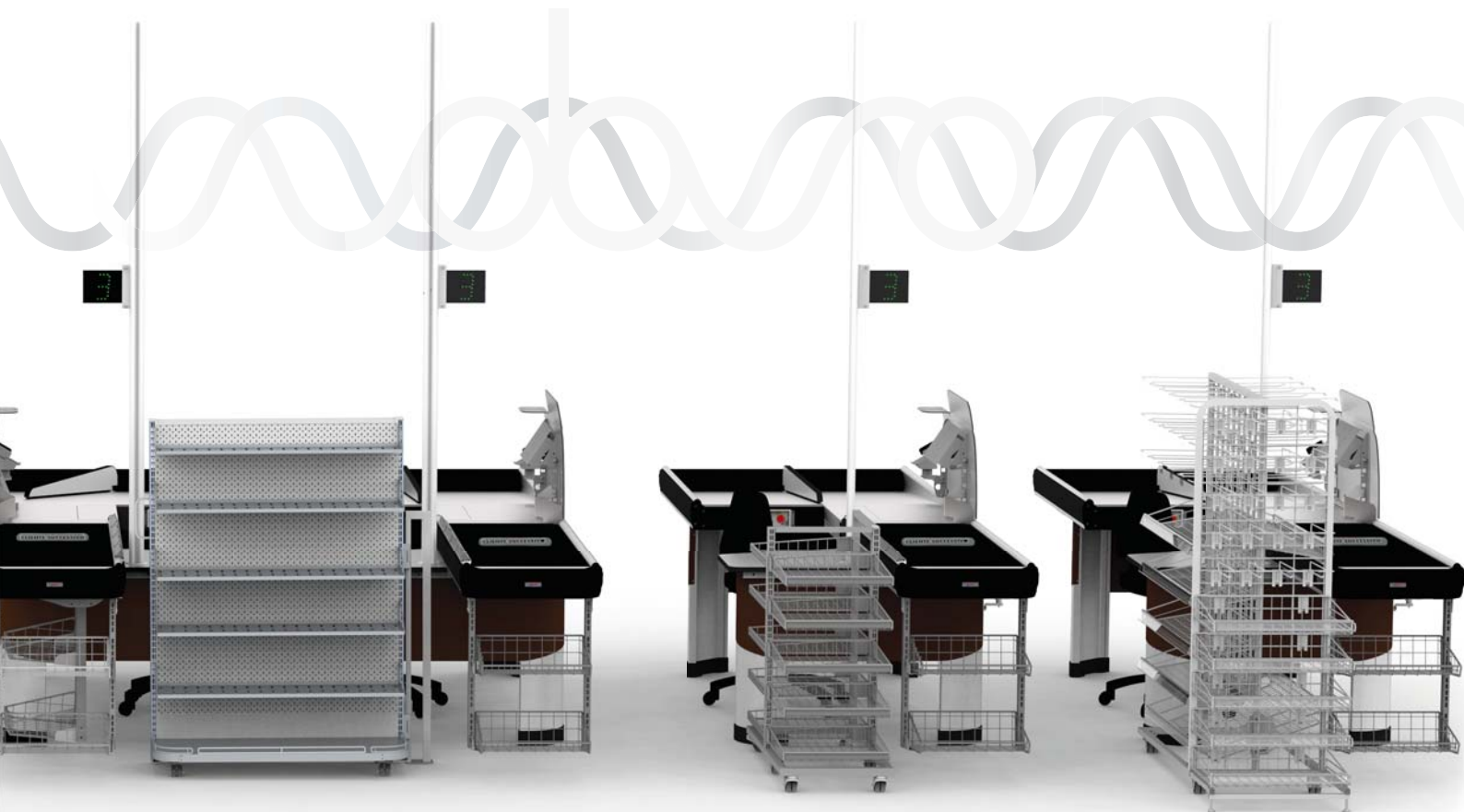

BTB-C

FLM

FLF-C

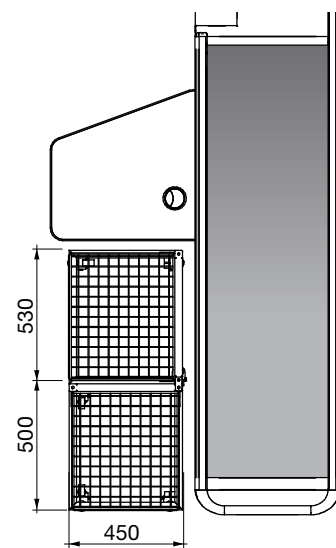
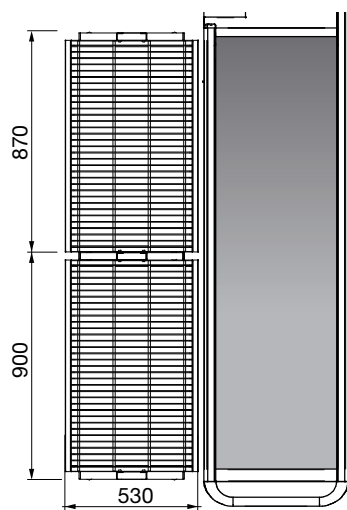
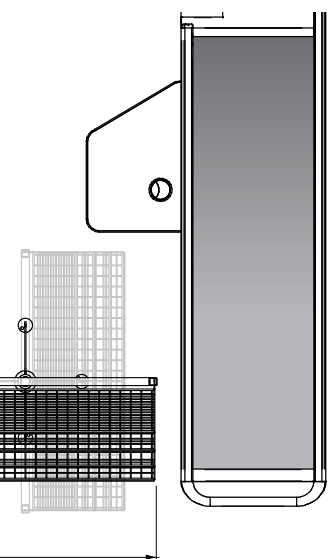
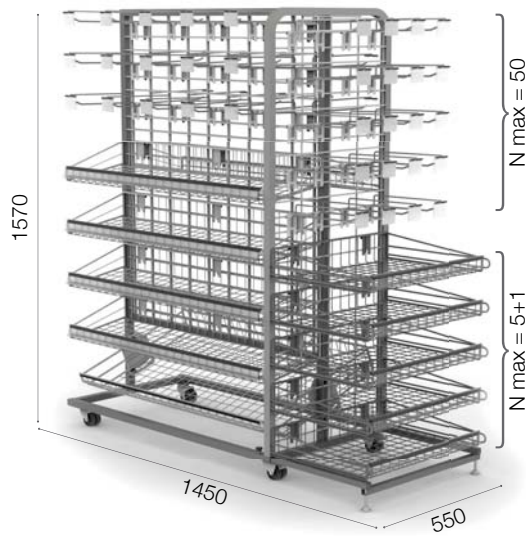
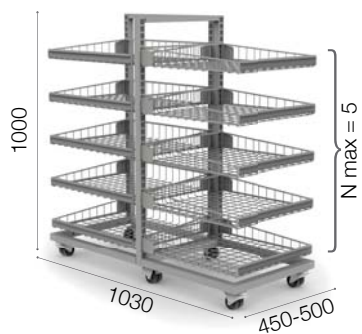
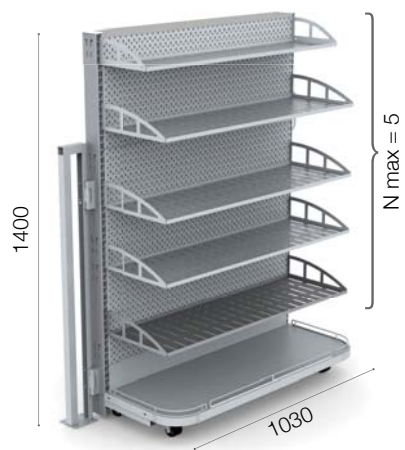



Tandem



BTB



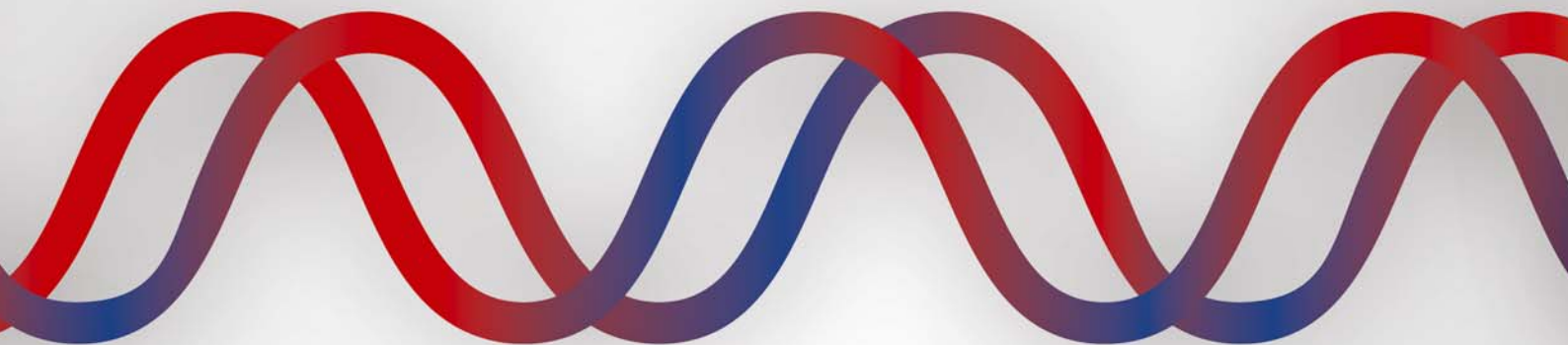

INTRAC

DESIGN & DISPLAY

45100 ROVIGO - Italy
Via A. Grandi, 24
Tel. +39 0425 363666
Fax +39 0425 363600

www.intrac.it - info@intrac.it



INTRAC Spa, la cui politica è quella di un continuo perfezionamento, si riserva il diritto di apportare in qualunque momento modifiche ai dati contenuti in questa pubblicazione senza obbligo alcuno di avviso preventivo. • INTRAC Spa, in line with its policy of constant improvement, reserves the right to modify the data included in this catalogue at any time and without notice. • Die Firma INTRAC Spa, deren Politik eine stetige Verbesserung ihrer Produkte ist, behält sich das Recht vor, in irgendeinem Augenblick Inhaltsänderungen, ohne vorherige Benachrichtigungspflicht, in dem vorliegenden Katalog vorzunehmen. • INTRAC Spa, dont la politique est celle d'un perfectionnement continu, se réserve le droit d'apporter des modifications n'importe quand aux données contenues dans ce catalogue, sans aucune obligation de préavis de notre part. • INTRAC Spa, cuja política de continuo aperfeiçoamento, reserva-se o direito de alterar em qualquer momento, a modificação de dados contidos nesta publicação, sem obrigação alguma de pré aviso. • INTRAC Spa, según su política de continuo refinamiento, se reserva el derecho de modificar los datos incluidos en este catálogo en cualquier momento y sin previo aviso. • Фирма INTRAC Spa, политикой которой является постоянное совершенство, оставляет за собой право изменить все данные этого каталога в любой момент, без предварительного уведомления.